

SYL-1512A PID TEMPEARATURE CONTROLLER INSTRUCTION MANUAL

Version 2.1

Jun. 2007

Auber Instruments, 730 Culworth, Alpharetta, GA 30022

www.auberins.com e-mail: auberins@gmail.com Tel: 404-291-6298



WARNING

·Wiring precautions

-Install an external protection circuit if failure of this instrument could result in damage to your system.

-In order to prevent instrument damage or failure, protect the power line and the input/output lines from high currents by using fuses with appropriate ratings.

·Power supply

-Supply power of the specified rating.

-Do not turn on the power until all of the wiring is completed.

-Never use this instrument in the presence of inflammable gases or vapor.

-In order to prevent electric shock or burns, never touch the inside of the instrument.

-Do not attempt to modify this instrument.

·Maintenance

-Only authorized service engineers should replace parts.

-In order to use this instrument continuously and safely, conduct periodic maintenance. Some parts used in this instrument have a limited service life and may deteriorate over time.



Caution

·Only clean the instrument when power is off.

·Please use a soft cloth or tissue to clean up stains on the display.

·Never use sharp & hard objects such as screwdrivers or ball pens to touch the buttons on the panel.

1. Features

- ◆ Compact size, 1/32 DIN that is only 24 x 48 x 75 mm (1x2 x3")
- ◆ Custom modified for espresso machine, offering small temperature overshoot and fast recover after shot.

2. Specification

- ◆ Power supply: 85~260VAC or 85~360VDC
- ◆ Power consumption: <2W
- ◆ Sampling rate: 4 sample/sec
- ◆ Accuracy: 0.2% full scale
- ◆ Display range: -1999~9999
- ◆ Display resolution: 1 °C ,1°F, or 0.1 °C ,0.1°F with Pt100 RTD sensor input.
- ◆ SSR driving output: 10VDC, 40 mA
- ◆ LED display: 0.28" red color
- ◆ Out of range display: "EEEE"
- ◆ Working condition: 0~50°C, ≤85%RH
- ◆ Relay contact rating: 220VAC @ 3A
- ◆ Outside dimensions: 48×24×75mm
- ◆ Mounting cutout dimension: 45×22mm

3. Front Panel and Operation

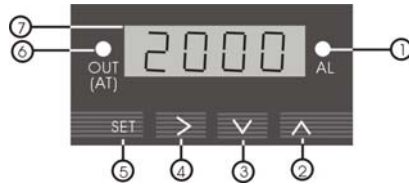

Figure 2

- ① AL- Relay J1 indicator
- ② Select next parameter/value increment.
- ③ Select previous parameter/value decrement
- ④ Digit shift/Auto tuning
- ⑤ Set/Confirm
- ⑥ OUT- Output indicator
(AT) - blinking during auto-tuning process
- ⑦ Parameter Display

4. Parameter Setting

a) Configuration Parameters

Table 1, Configuration Parameter Setting

Code	Description	Setting Range	Initial Setting	Note	
Inty	Inty	Input Type	See table 2	K	
outy	outy	Controlled output device	0, 1, 2	2	1
Atdu	Atdu	Autotune offset	0~200(deg)	10	2
PSb	PSb	Input offset	-100~100(deg)	0	
rd	rd	Control function	0: heating 1: Cooling	0	
CorF	CorF	Display Unit	0: °C 1: °F	1	
End	End	Exit			

Note 1. 0: Relay J1 as alarm output; SSR output disabled. Can be used as On/Off control.

1: Relay J1 as PID controlled relay contact output. SSR output disabled.

2: Relay J1 as alarm output; SSR PID controlled with 12 V output.

Note 2. The autotune offset will shift the SV value down by the the Atdu value during the auto tune process. That will preventing the system from damaging from over temperature during the autotune.

Press (SET), The enter code “0089” press (SET) again. Then, following the flow chart in Fig. 3

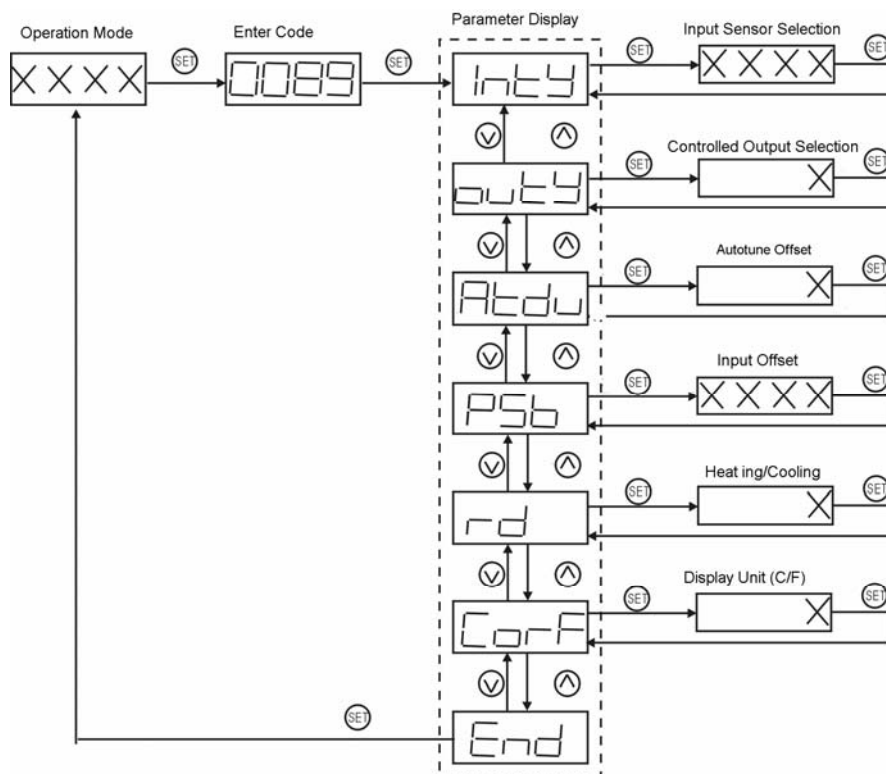

Figure 3 Setup flow chart

- 1) Press to enter setting mode;
- 2) Press , and to enter parameters;
- 3) Press to confirm;
- 4) Press or to select the new parameter

Table 2, Temperature sensor code.

Symbol	Description	Working Temperature Range
t	T Thermocouple	-200~400 °C; -320~752 °F
r	R Thermocouple	-50~1600 °C; -58~2900 °F
j	J Thermocouple	-200~1200°C; -320~2200 °F
WRE	WRe3- WRe25 Thermocouple	0~2300°C; 32~4200 °F
b	B Thermocouple	350~1800°C; 660~3300 °F
S	S Thermocouple	-50~1600°C; -58~2900 °F
K	K Thermocouple	-200~1300°C; -320~2400 °F
E	E Thermocouple	-200~900°C; -320~1650 °F
P10.0	Pt100 RTD	-99.9~600.0°C; -99.9~999.9 °F
P100	Pt100 RTD	-200~600°C; -320~1100 °F
Cu50	Cu50 RTD	-50.0~150.0°C; -60~300 °F

b) PID Parameters

To enter PID parameter setting mode, press , then enter code “0036”, press again. The parameter flow chart is similar to Fig. 3

Table 3, PID and relevant parameters

Symbol	Description	Setting range	Initial Setting	note
P	Proportional	0.1~99.9 (%)	5.0	4

		Constant			
I	I	Integral time	2~1999(Sec)	100	5
d	d	Derivative time	0~399(Sec)	20	6
SouF	SouF	Damp constant	0.1~1.0	0.2	7
ot	ot	Cycle rate	2~199(sec)	2	8
FILT	FILT	Digital filter strength	0~3	0	9
End	End	Exit			

The values of the P, I, and D parameters are critical for good response time, accuracy and stability of the system. Using the Auto-Tune function to automatically determine these parameters is recommended for the first time user. If the auto tuning result is not satisfactory, you can manually fine-tune the PID constants for improved performance.

Note 4. Proportional Constant (P): Represents the gain of the signal amplifier. Larger gain means the controller will have more output power change for the same difference between set temperature (SV) and measured temperature (PV). Smaller P value represents higher gain, or faster action.

Note 5. Integration time (I): Brings the system up to the set value by adding a constant to the output that is proportional to how far the process value (PV) is from the set value (SV) and how long it has been there. When I decreases, response speed is faster but the system is less stable. When I increases, respond speed is slower, but system is more stable.

Note 6. Differentiation time (d): Responds to the rate of change of the process value so that the controller can compensate in advance before |SV-PV| gets too big. A larger number increases its action. Setting d-value too small or too large would decrease system stability, causing oscillation or even non-convergence.

Note 7. This function is deactivated for the espresso kit.

Note 8. Control Period (also called cycle rate) (ot): When ot gets smaller, heating/cooling cycle is drive faster, system respond speed is faster. For SSR output, ot is normally set at 2. But when using contact control (Relays), contacts wear out faster so it is normally at 5~30 seconds.

Note 9. Digital Filtering (Filt): Filt=0, filter disabled; Filt=1, weak filtering effect; Filt=3, strongest filtering effect. Stronger filtering increases the stability of the readout display, but causes more delay in the response to changes in temperature.

c) Temperature setting and Alarm setting



To enter the temperature and alarm parameter setting mode, press , enter the code “0001”, and press  again. The parameter flow chart is shown in Fig. 3

Table 4. Temperature and Alarm Parameter

Symbol		Description	Initial setting	Note
Sv	SV	Target temperature (Set Value)	800	11
AH1	AH1	Alarm on temperature	800	
AL1	AL1	Alarm off temperature	900	
End	End	Exit		

Note 11. The SV can also be set directly during the normal operation mode. Press (^) or (v) key to switch the display from process value (PV) to set value (SV). Press (^) or (v) key again to increase or decrease SV

by 1 degree.

i. Relay J1 value

- ① When $AH1=AL1$, relay is disabled,
- ② $AH1 > AL1$ is for absolute high alarm. See fig. 4.
- ③ $AH1 < AL1$ is for absolute low alarm. See fig. 5.

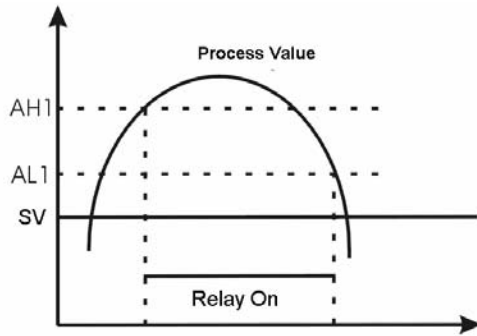

Figure 4

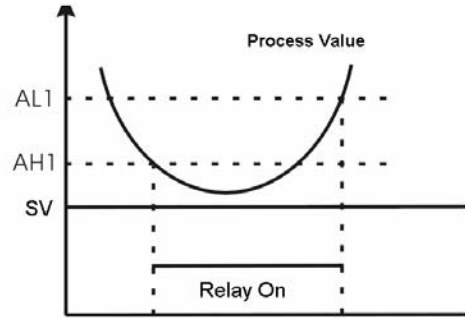

Figure 5

5. Auto-Tuning

Auto-Tuning function (also called self tuning) can automatically optimize the PID parameters for the system. The auto-tuning function will heat up the system then let it cool down. It will repeat several times. Based on the response time of the system, the built-in artificial intelligence program will calculate and set the PID parameters for the controller.

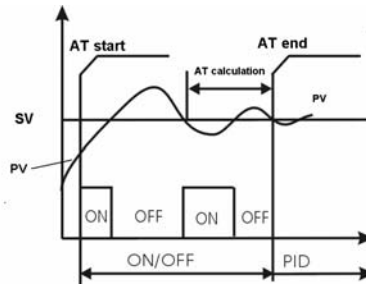

Figure 6

A) To activate auto-tuning, press and hold \odot key until the “AT” indicator starts to blink, which indicates auto-tuning is in progress. When “AT” stops blinking, the auto-tuning is finished. Now, newly calculated PID parameters are set and are used for the system. Please note that Auto-tuning is only for PID control mode (when “outy” is set at 1 or 2)

B) To stop the auto-tuning, press and hold \odot key until “AT” indicator stops blinking. Then, the previous PID parameters value are resumed.

6. Terminal Wiring (back view)

The polarity of power at terminal 1 and 2 do not matter.

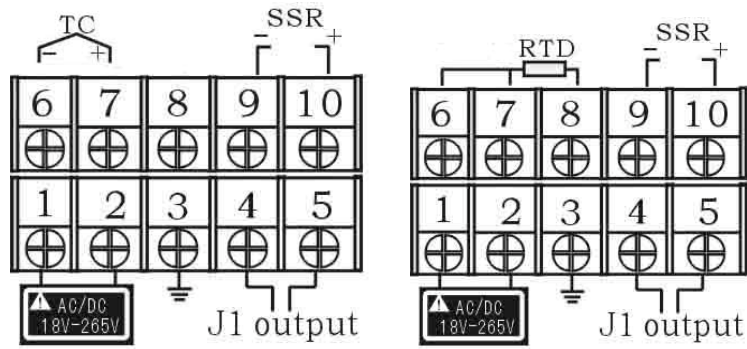

Figure 7. Wiring diagram with thermocouple (TC) input on the left and RTD input on the right. Please note that if the RTD is connected by two wires instead of three wires (for short distance application), the terminal 6 and 7 need to be shorted.